

# TAKE THE BEST

Decades of quality from Austria! [www.sihga.com](http://www.sihga.com)



## SIHGA<sup>®</sup> MONITORIX<sup>®</sup> TOTAL ASSEMBLY INSTRUCTIONS

# FUNCTION OVERVIEW

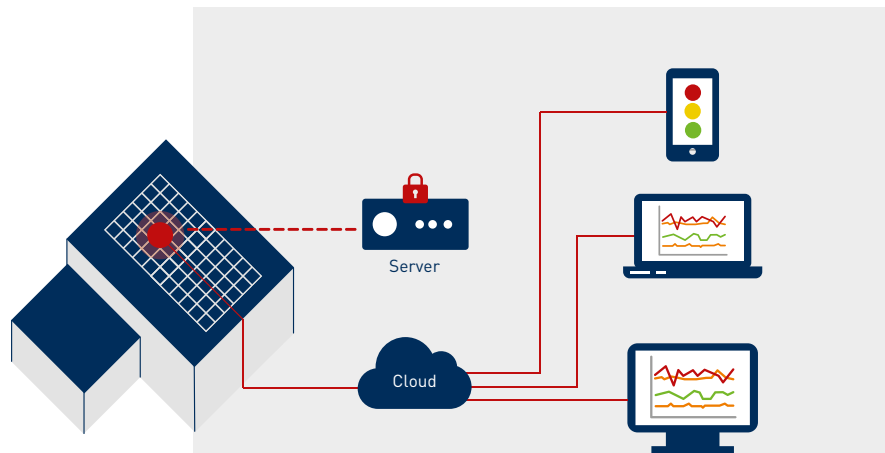

**1** Permanent, comprehensive data collection

**2** Data transmission in to server in real time

**3** Automatic data preparation

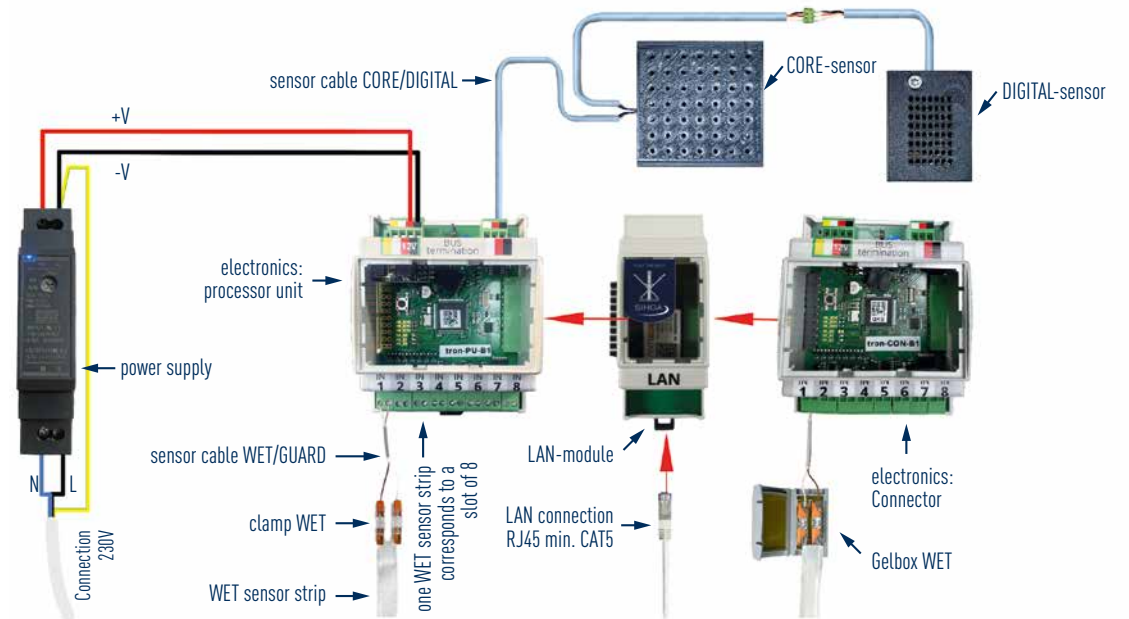

#TAKETHEBEST  
#TAKESIHGA





# TABLE OF CONTENTS

---

1. Packaging overview	page 4
2. Assembly sequence	page 5
3. Product explanation	page 6 - 19

# PACKAGING OVERVIEW

1

## VP 1 (Packaging):

WET sensor | DIGITAL-sensor | CORE-sensor | clamps | gelbox | tape

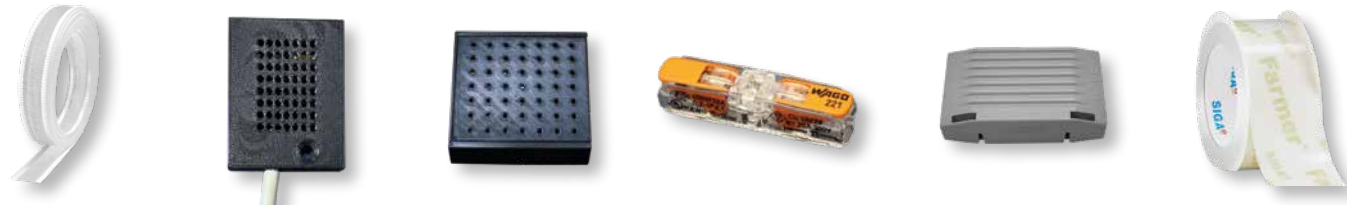

2

## VP 2 (Packaging):

sensor cable



3

## VP 3 (Packaging):

power supply | LAN-module | processor unit tron-PU | connector tron-CON



# ASSEMBLY SEQUENCE

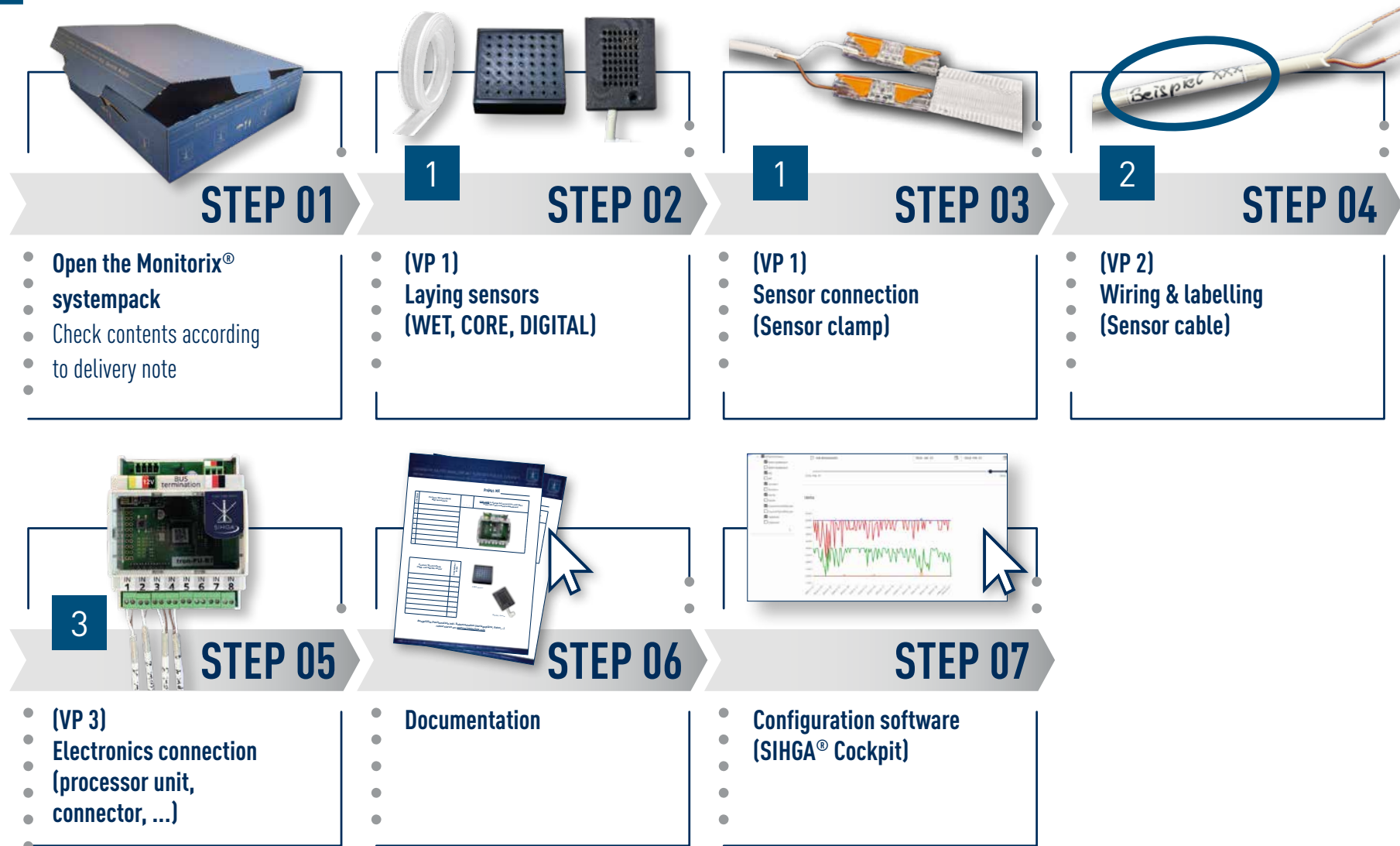



# WET



TAKE THE BEST™



www.sihga.com

## Monitorix® WET

INNOVATIVE CONSTRUCTION TECHNOLOGY  
AND SUPPORT FOR THE FUTURE

MA Nr. 60301/24/10/EN

TAKE THE BEST™





Assembly video



SIHGA® GmbH | Gewerbestraße Kleinreith 4 | 4694 Ohlsdorf bei Gmunden | AUSTRIA  
Tel.: +43 7612 / 74 370 - 0 | E-Mail: info@sihga.com | www.sihga.com

### 1

Packaging unit: 25 m / 100 m  
Maximum length of a WET sensor strip: 20 m  
Sensor width: 22 mm

Do not open the packaging  Cut off the required length 

One WET sensor strip -> one slot on the electronics.  
WET sensor strips can be split.

### 2

Define installation

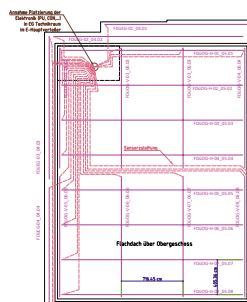

Transfer the installation plan to the area where the sensors are to be installed.

### 3

Laying the WET sensor strip



At start and end points as well as corner and crossing points, create a separating layer to the substrate!





Fastening approx. every 2 m  
(no separating layer necessary)

### 4

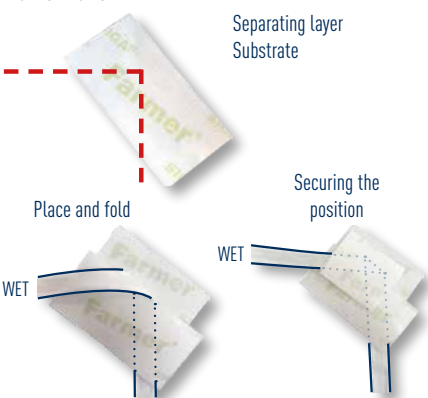
Corner formation



Separating layer  
Substrate

Place and fold  Securing the position 



WET

### 5

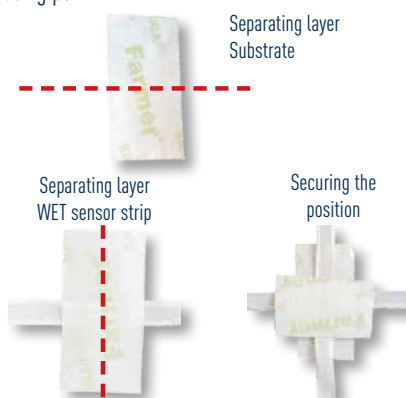
Crossing point

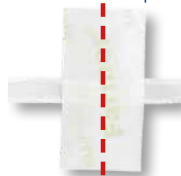

Separating layer  
Substrate

Separating layer  
WET sensor strip  Securing the position 

### 6

Accessories



Sensor clamp



Gelbox



Sensor cable WET-/GUARD



Adhesive tape

# WET

### 7

WET sensor strip -> sensor cable connection WET/-GUARD

Expose the sensor wire (approx. 11 mm)

Open sensor clamp

Strip 2-pole insulation from sensor cable (approx. 11 mm)

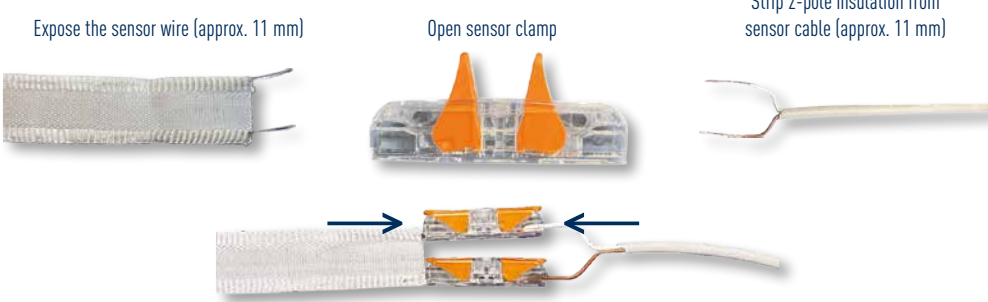

**NOTE:** The WET sensor strip can also be cut into pieces.  
Example: 5 linear metres of WET sensor strip - sensor terminals - sensor cable WET/-GUARD - sensor terminals - 5 linear metres of WET sensor strip

### 8

Terminal points / connection

- make connections on the sensor side
- open gelbox
- place sensor terminals in gelbox

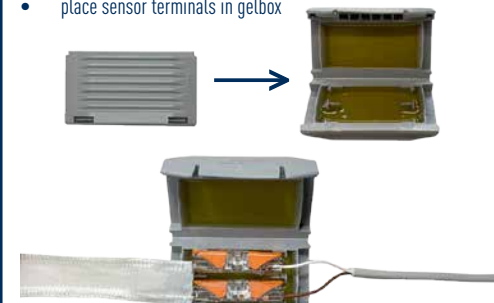

### 9

Terminal points / connection

- close the gelbox and form a relief loop
- secure position (e.g. adhesive tape)

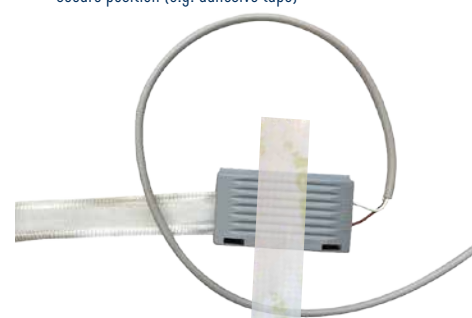

### 10

Laying the sensor cable WET/-GUARD

Sensor cables WET/-GUARD are routed from the WET sensor strip to the electronics (processor unit or connector). Ensure that the cables are laid neatly and tidily.

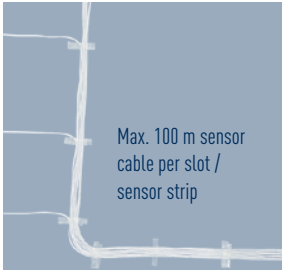

Max. 100 m sensor cable per slot / sensor strip

### 11

Labelling sensor cable WET/-GUARD

Use the Monitorix stickers supplied with the cables (VP 2) for easier cable labelling.

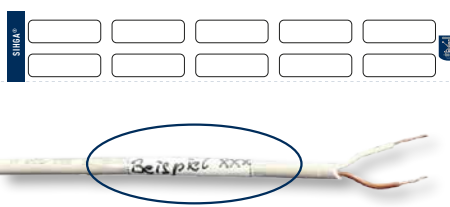

### 12

Connecting the electronics to processor unit

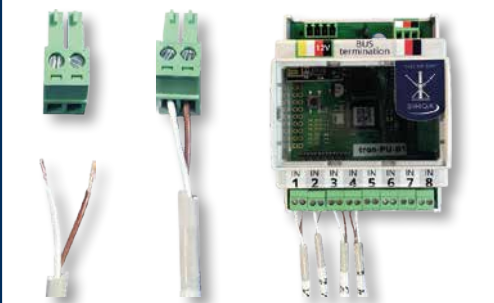

### 13

Documentation

Complete the attached form (item list!)

Send the completed form including image documentation to [monitoring@sihga.com](mailto:monitoring@sihga.com) or upload it to the SIHGA® Cockpit!

Download: <https://www.sihga.com/service/download/monitorix/>



# DIGITAL-SENSOR



TAKE THE BEST<sup>®</sup>  
SIHGA  
www.sihga.com

**Monitorix<sup>®</sup> DIGITAL-sensor**  
INNOVATIVE CONSTRUCTION TECHNOLOGY  
AND SUPPORT FOR THE FUTURE

MA Nr. 60031/24/10/EN

TAKE THE BEST



Assembly video

Facebook YouTube Instagram LinkedIn

SIHGA<sup>®</sup> GmbH | Gewerbehark Kleinreith 4 | 4694 Ohtsdorf bei Gmunden | AUSTRIA  
Tel.: +43 7612 / 74 370 - 0 | E-Mail: info@sihga.com | www.sihga.com

**1**

Packaging unit: 1 pc  
Dimensions:  
Length: 42 mm  
Width: 55 mm  
Height: 12 mm

The DIGITAL-sensor is used for localised detection of humidity and temperature.

Measuring ranges:  
Humidity: 0-100 %  
Temperature: -40 °C bis 100 °C

**2**

The Monitorix DIGITAL-sensor includes

- 01 1x connection (LIN-BUS) to the electronics
- 02 1x serial number
- 03 Ø 5 mm hole with countersink as mounting option
- 04 Plastic housing with integrated electronics
- 05 Pre-contacted screw terminal

**3**

Connections and components

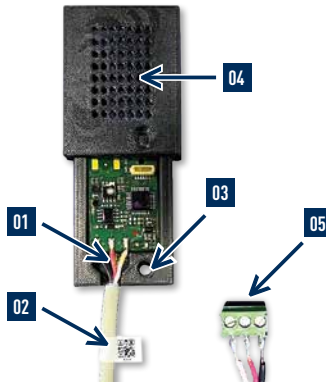

**4**

Connecting the sensor cable CORE/-DIGITAL to the DIGITAL-sensor

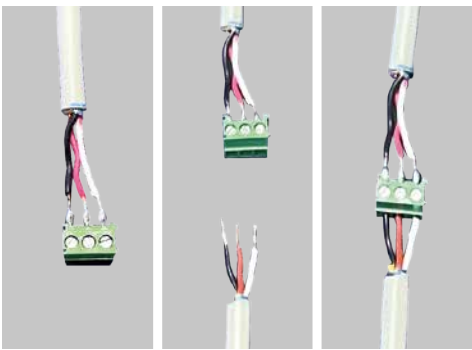

**5**

Connection of sensor cable CORE/-DIGITAL to electronics (processor unit or connector)

Up to 8 pieces per electronics



**6**

The DIGITAL-sensor can be connected in a star-shaped arrangement

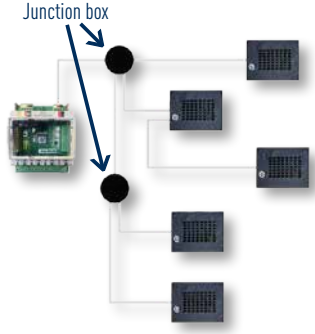



# DIGITAL-SENSOR

7

## Assembly

**Do not** open cover



8

## Assembly

Fastening the DIGITAL-sensor  
Maximum cross-section of the screw 4.5 mm



9

## Assembly

Final assembly condition



10

## Assembly

Cover the supplied heat-shrink tubing to protect the screw terminal ...

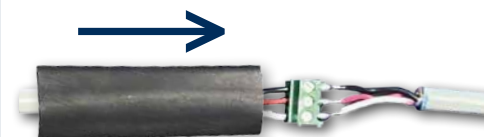

11

## Assembly

... and heat up until it fits cleanly



12

The documentation must be stored in the cockpit after completion.

Position / Description CORE and DIGITAL sensor	Serial number

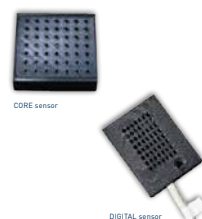

Template for download at  
<https://www.sihga.com/en/service/download/monitorix/>

13

Document the serial number of the respective device



14

## ! Note !

Proper documentation is required to ensure the correct assignment of sensors in the cockpit



# CORE-SENSOR



TAKE THE BEST™  
SIHGA  
www.sihga.com

## Monitorix® CORE-sensor

INNOVATIVE CONSTRUCTION TECHNOLOGY  
AND SUPPORT FOR THE FUTURE

MA Nr. 60312/24/10/EN

TAKE THE BEST



Assembly video

f y i n

SIHGA® GmbH | Gewerbehark Kleinreith 4 | 4694 Ohlsdorf bei Gmunden | AUSTRIA  
Tel.: +43 7612 / 74 370 - 0 | E-Mail: info@sihga.com | www.sihga.com

**1**

Packaging unit: 1 pcs.  
Dimensions:  
Length: 57 mm  
Width: 57 mm  
Height: 15 mm

The CORE-sensor is used for the selective detection of wood moisture, humidity and temperature.

Measuring ranges:  
Humidity: 0 - 100 %  
Temperature: -40° to 100°  
Wood moisture: 6% - 30%  
Measuring depth: 0 - 40 mm (Standard on request - 120 mm)

**2**

The Monitorix CORE-sensor includes:

- 01** 1x connection (LIN-BUS) to the electronics
- 02** 2x gold-plated contacts for spring / mounting holes
- 03** 1x Serial number
- 04** 2x Sensor screw 5.0 x 45 mm
- 05** 2x Washer for mounting the spring
- 06** 2x Spring to compensate for shrinkage and swelling of the wood

**3**

Connections and components

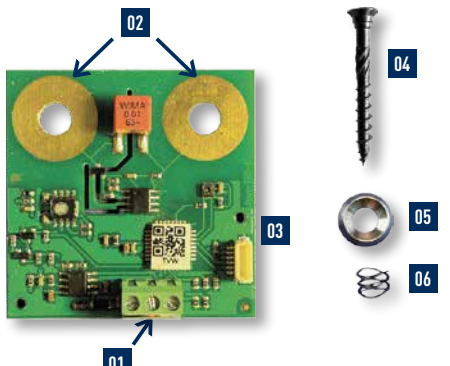

**4**

Connecting the sensor cable CORE-/DIGITAL to the CORE-sensor

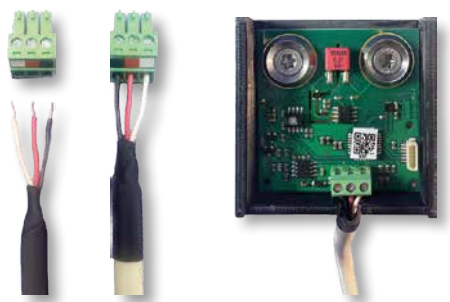

**5**

Connecting the sensor cable CORE-/DIGITAL to the electronics (processor unit or connector)

Up to 8 pieces per electronics



**6**

CORE-sensor connection possible in a star-shaped arrangement

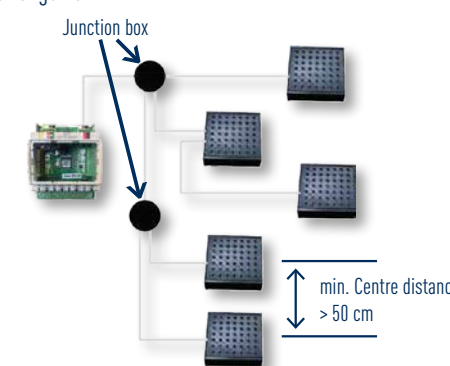

min. Centre distance > 50 cm

# CORE-SENSOR

7

Assembly

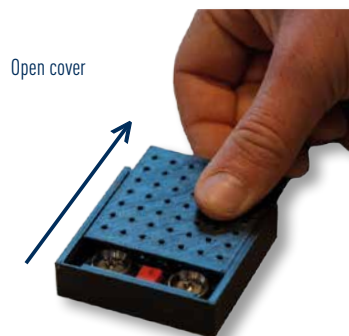

8

Assembly

Attaching the CORE-sensor



9

Assembly

Fastening 90° to the surface  
Compress springs to max. 4 mm

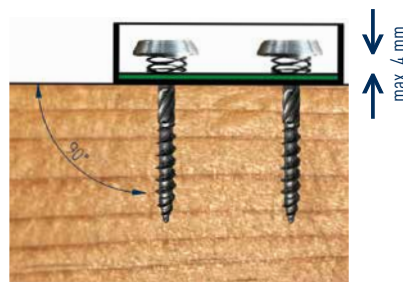

10

Assembly

Final assembly condition

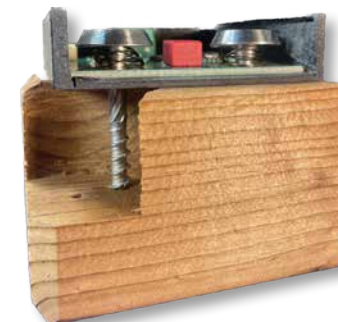

11

Assembly

CORE-sensor attached incl. sensor cable CORE/-DIGITAL connection

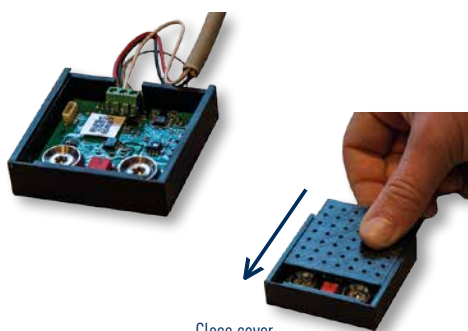

12

After completion, the documentation must be sent to [monitoring@sihga.com](mailto:monitoring@sihga.com) after completion

Position / Description CORE and DIGITAL sensor	Serial number sensor

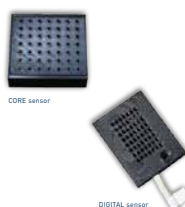

Template for download at  
<https://www.sihga.com/en/service/download/monitorix/>

13

Document the serial number of the respective device



14

**! Note !**

**Proper documentation is required to ensure the correct assignment of sensors in the cockpit**





# POWER SUPPLY



TAKE THE BEST<sup>™</sup>  
SIHGA  
www.sihga.com

**Monitorix<sup>®</sup> power supply**  
INNOVATIVE CONSTRUCTION TECHNOLOGY  
AND SUPPORT FOR THE FUTURE

MA Nr. 60308/24/10/EN

TAKE THE BEST



Assembly video

f y t i n

SIHGA<sup>®</sup> GmbH | Gewerbestraße Kleinreith 4 | 4694 Ohltdorf bei Gmunden | AUSTRIA  
Tel.: +43 7612 / 74 370 - 0 | E-Mail: info@sihga.com | www.sihga.com

**1**

Packaging unit: 1 pc  
Top-hat rail mounting possible  
On top-hat rail: 1 DU\*

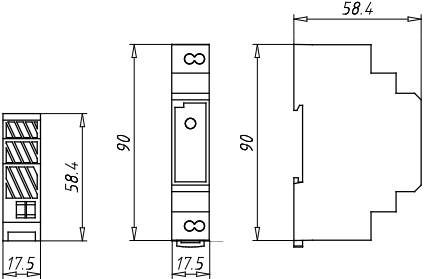

\*DU= Dividing unit (18 mm)

**2**



**3** Connection to electronics

power supply processor unit LAN-module



**5** Power supply connection detail



**4** Mains connection

**! ATTENTION! 230V connection may only be by a qualified electrician**



Low voltage 12V  
**V+** red + 12V  
**V-** black - 12V

230V  
**N** neutral conductor  
**L** phase  
**PE** earthing/functional earthing is clamped to V-

**6** Power supply status LED

□ currentless  
 ■ under voltage



# LAN-MODULE



www.sihga.com

## Monitorix® LAN-module

INNOVATIVE CONSTRUCTION TECHNOLOGY  
AND SUPPORT FOR THE FUTURE

MA Nr. 60309/24/10/EN

TAKE THE BEST



Assembly video



SIHGA® GmbH | Gewerbepark Kleinreith 4 | 4694 Ohlsdorf bei Gmunden | AUSTRIA  
Tel.: +43 7612 / 74 370 - 0 | E-Mail: info@sihga.com | www.sihga.com

1

Packaging unit:  
Top-hat rail mounting possible  
On top hat rail:

1 pc

2 DU\*

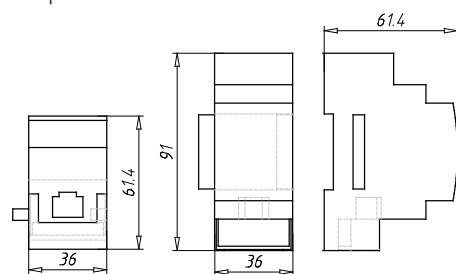

\*DU= Dividing unit (18 mm)

2

Network requirements:

- LAN connection via RJ45 cable 10/100 Mbps to a router a router (no POE).
- DHCP server must provide IP address.
- DHCP must also provide valid DNS.
- Network connection must not require a proxy.
- Required outgoing ports in Internet:  
80 TCP, 443 TCP, 53 UDP/TCP,  
123 UDP/TCP, ICMP
- Incoming connections are not carried out -  
No NAT forwarding necessary

3

Tool-free assembly:

- 01 Plug connection (female) for connector
- 02 Plug connection (male) to processor unit
- 03 Plug connection for network (LAN cable)



4

Connection:

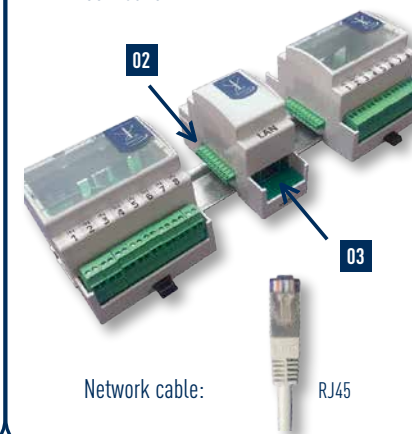

Network cable: RJ45

5

Connection to electronics:

power supply processor unit LAN-module



6

LAN-status-LED:

LED lights up or flashes when connected to router/network

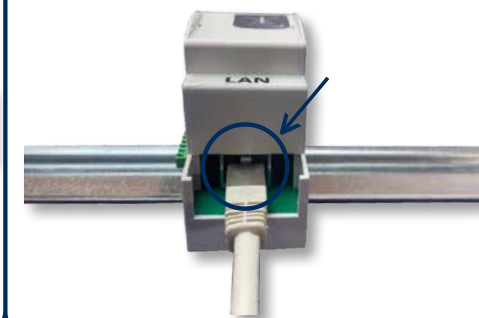

# PROCESSOR UNIT TRON-PU

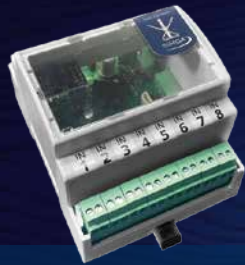

## Monitorix<sup>®</sup> processor unit tron-PU

INNOVATIVE CONSTRUCTION TECHNOLOGY  
AND SUPPORT FOR THE FUTURE

MA Nr. 60310/24/10/EN

TAKE THE BEST



Assembly video



SIHGA<sup>®</sup> GmbH | Gewerbehark Kleinreith 4 | 4694 Ohlsdorf bei Gmunden | AUSTRIA  
Tel.: +43 7612 / 74 370 - 0 | E-Mail: info@sihga.com | www.sihga.com

1

Packaging unit: 1 pc  
Top-hat rail mounting possible  
On top-hat rail: 4 DU\*

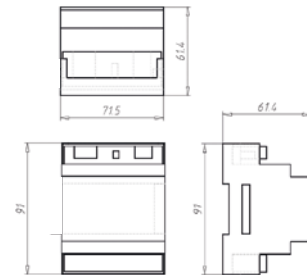

\* DU = Dividing unit (18 mm)

2

The Monitorix<sup>®</sup> processor unit includes:

- 01 8x Slot for sensor strips (Monitorix<sup>®</sup> WET)
- 02 1x Slot (LIN-BUS) for up to 8 pcs. Monitorix<sup>®</sup> CORE or 8 pcs. Monitorix<sup>®</sup> DIGITAL sensor (mix possible)
- 03 1x connection for power supply and CAN-BUS connection
- 04 1x jumper for CAN-BUS (terminating resistor)
- 05 Serial number (in the housing under QR code)
- 06 1x plug connection for Monitorix<sup>®</sup> LAN-module (female)

3

Plug connection for mounting

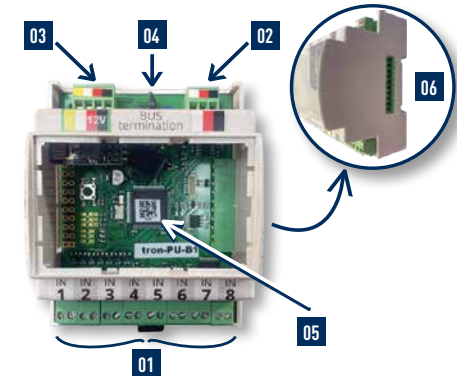

4

Connecting the electronics

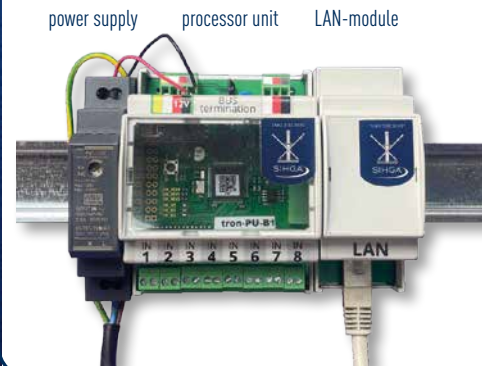

5

Accessories

1. Extension with additional sensor strips  
Monitorix<sup>®</sup> connector Art. No. 60081
2. Establishing an Internet connection  
Monitorix<sup>®</sup> LAN-module Art. No. 60011
3. Production of power supply  
Monitorix<sup>®</sup> power supply Art. No. 60041

6

Accessories





# PROCESSOR UNIT TRON-PU

7

After installing and connecting the sensor tracks, connect the WET sensor cable to one of the 8 slots



Enter assignment in item list (see Fig. 11)

8

Connection of WET sensor cable to processor unit electronics

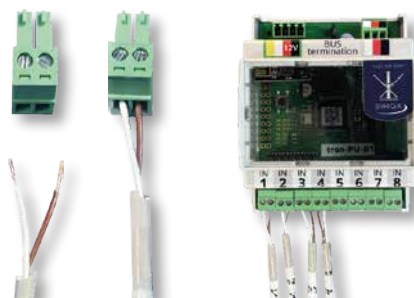

9

Connection of sensor cable CORE or DIGITAL sensor to processor unit electronics

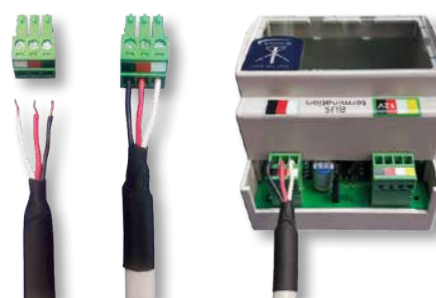

10

Mains connection according to power supply instructions

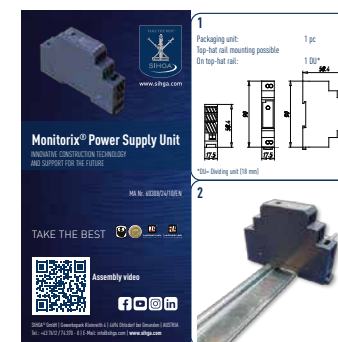

11

After completion, the documentation must be sent to [monitorix@sihga.com](mailto:monitorix@sihga.com)

Pos	Position / Description WET sensor path	tron-PU enter 3-digit serial number (under QR code in electronics housing)
1		
2		
3		
4		
5		
6		
7		
8		



Template for download at:  
<https://www.sihga.com/service/download/monitorix>

12

Documentation

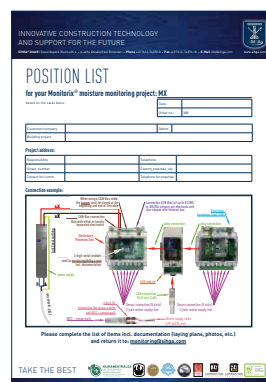

13

Document the serial number of the respective device

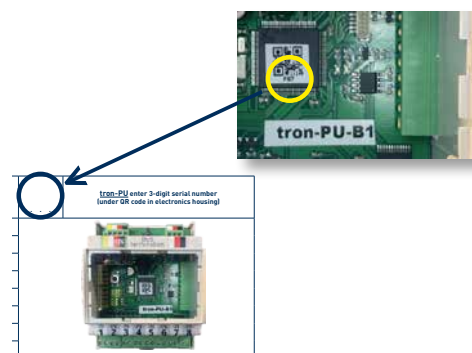

14

**! Note !**  
Proper documentation is required to ensure the correct assignment of sensors in the cockpit



# CONNECTOR TRON-CON



## Monitorix® connector tron-CON

INNOVATIVE CONSTRUCTION TECHNOLOGY  
AND SUPPORT FOR THE FUTURE

MA Nr. 60311/24/10/EN

TAKE THE BEST



Assembly video



SIHGA® GmbH | Gewerbestraße 4 | 4694 Ohlsdorf bei Gmunden | AUSTRIA  
Tel.: +43 7612 / 74 370 - 0 | E-Mail: info@sihga.com | www.sihga.com

1

Packaging unit: 1 pc  
Top-hat rail mounting possible  
On top-hat rail: 4 DU\*

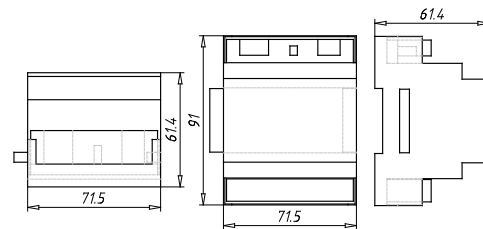

\*DU= Dividing unit (18 mm)

2

The Monitorix connector includes

- 01 8x slot for sensor strips (Monitorix WET)
- 02 1x slot (LIN-BUS) for up to 8 pcs. Monitorix CORE or 8 Monitorix DIGITAL-sensor (mix possible)
- 03 1x Connection for power supply and CAN-BUS connection
- 04 1x jumper for CAN-BUS (terminating resistor)
- 05 serial number (in the housing under QR code)
- 06 1x plug connection (male) to Monitorix LAN-module
- 07 1x plug connection (female) to further Monitorix connector

3

Plug connection for mounting

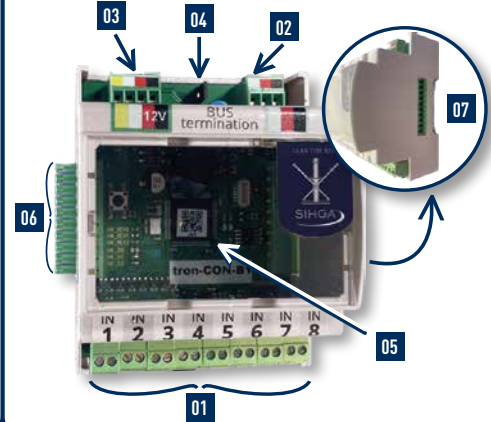

4a

Connecting the electronics  
Serial connection

power supply processor unit LAN-module connector

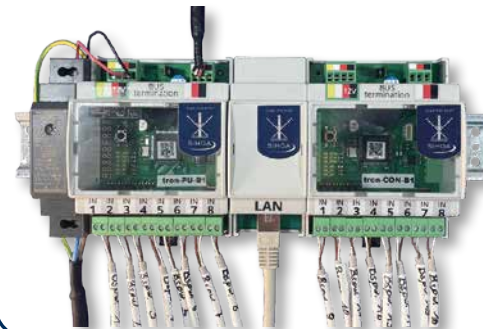

4b

Connecting the electronics  
BUS connection

power supply processor unit LAN-module connector

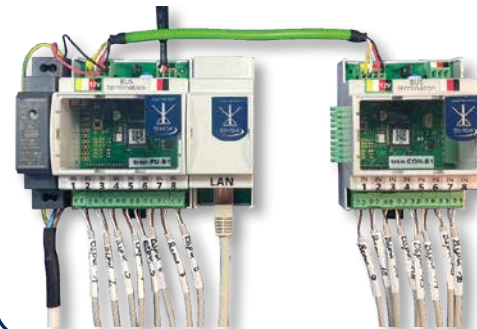

5

Start and end of the BUS cable using  
close jumper

Jumper open  
(horizontal)

Jumper closed  
(vertical)



# CONNECTOR TRON-CON

6 Example of use: BUS line

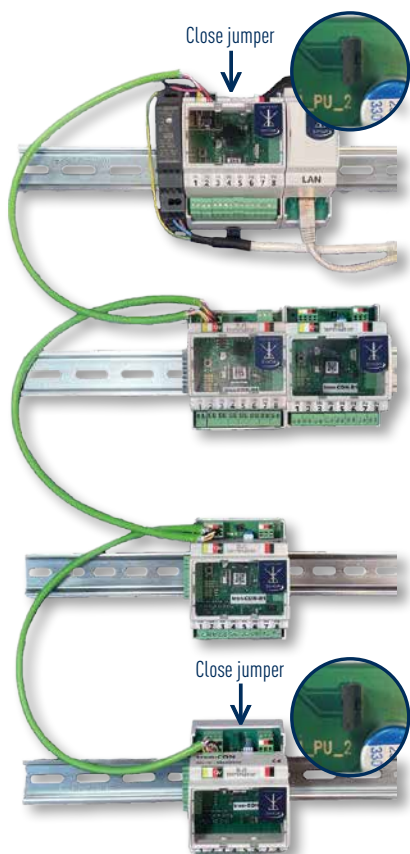

Note: max. 13 connectors per processor unit

7 Connecting the WET sensor cable to the connector

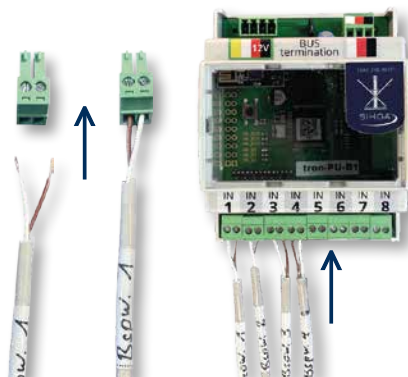

8 Sensor cable connection CORE- or DIGITAL-sensor to connector

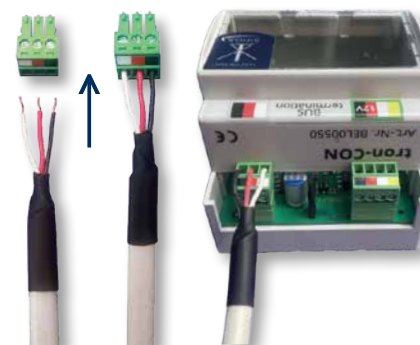

9 Connection of BUS cable to processor unit or connector

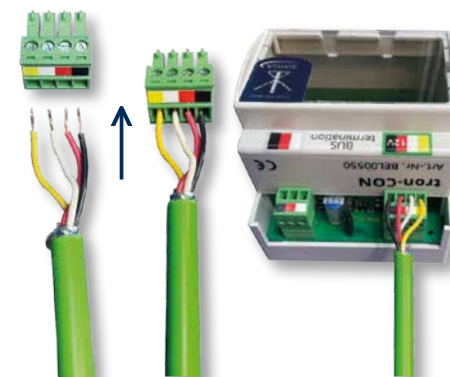

10 The documentation must be sent to [monitoring@sihga.com](mailto:monitoring@sihga.com) upon completion.

№	Position / Description WET sensor path	tron-CON enter 3-digit serial number (under QR code in electronics housing)
1		
2		
3		
4		
5		
6		
7		
8		



Template available for download at [www.sihga.com/service/download/monitorix/](http://www.sihga.com/service/download/monitorix/)

11 Document the serial number of the respective device.



tron-CON enter 3-digit serial number  
(under QR code in electronics housing)



12

**! Note !**

Proper documentation is required to ensure the correct assignment of sensors in the cockpit.



# SENSOR CABLE WET



## Monitorix® sensor cable WET/GUARD

INNOVATIVE CONSTRUCTION TECHNOLOGY  
AND SUPPORT FOR THE FUTURE

MA Nr. 60303/24/10/EN

TAKE THE BEST



Assembly video



SIHGA® GmbH | Gewerbepark Kleinreith 4 | 4694 Ohlsdorf bei Gmunden | AUSTRIA  
Tel.: +43 7612 / 74 370 - 0 | E-Mail: info@sihga.com | [www.sihga.com](http://www.sihga.com)

1

Packaging unit: 100 m / 500 m  
Max. length of a sensor cable: 100 m  
Diameter: 4,2 mm  
Type: LiYY 2 x 0,25mm<sup>2</sup>



2

Application example

clamp

electronic

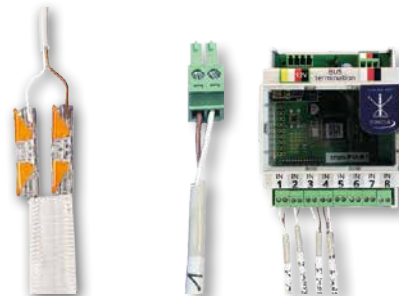

# SENSOR CLAMP WET



## Monitorix® clamp WET

INNOVATIVE CONSTRUCTION TECHNOLOGY  
AND SUPPORT FOR THE FUTURE

MA Nr. 60304/24/10/EN

TAKE THE BEST



Assembly video



SIHGA® GmbH | Gewerbepark Kleinreith 4 | 4694 Ohlsdorf bei Gmunden | AUSTRIA  
Tel.: +43 7612 / 74 370 - 0 | E-Mail: info@sihga.com | [www.sihga.com](http://www.sihga.com)

1

Packaging unit: 20 pc / 60 pc  
L / W / H (in mm) 36 x 8 x 8

closed



open



2

Application example

clamp





# GELBOX

# SENSOR CABLE CORE / DIGITAL



www.sihga.com

## Monitorix® Gelbox

INNOVATIVE CONSTRUCTION TECHNOLOGY AND SUPPORT FOR THE FUTURE

MA Nr. 60318/24/10/EN

TAKE THE BEST



Assembly video



SIHGA® GmbH | Gewerbepark Kleinreith 4 | 4694 Ohlsdorf bei Gmunden | AUSTRIA  
Tel.: +43 7612 / 74 370 - 0 | E-Mail: info@sihga.com | www.sihga.com

**1**

Packaging unit: 10 pc / 30 pc  
Width x height x depth: 32,7 x 17,8 x 56,9 mm  
Protection class: IPX8

Terminal points / connection

- make connections on the sensor side
- open gelbox
- place sensor terminals in gelbox

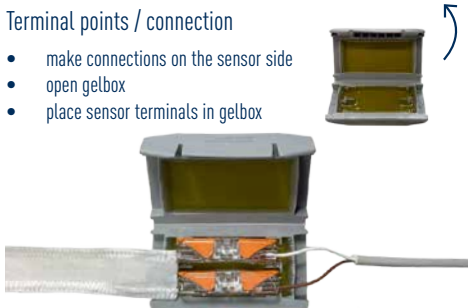

**2**

Terminal points / connection

- close the gelbox and form a relief loop
- secure position (e.g. adhesive tape)

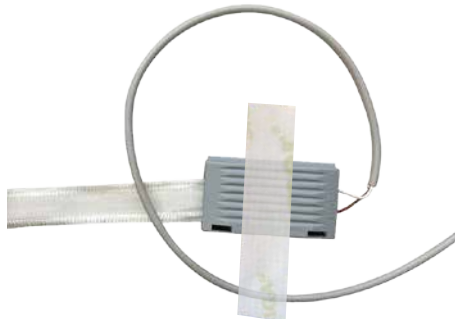



www.sihga.com

## Monitorix® sensor cable CORE/DIGITAL

INNOVATIVE CONSTRUCTION TECHNOLOGY AND SUPPORT FOR THE FUTURE

MA Nr. 60306/24/10/EN

TAKE THE BEST



Assembly video



SIHGA® GmbH | Gewerbepark Kleinreith 4 | 4694 Ohlsdorf bei Gmunden | AUSTRIA  
Tel.: +43 7612 / 74 370 - 0 | E-Mail: info@sihga.com | www.sihga.com

**1**

Packaging unit: 100 m / 500 m  
Max. length of a sensor cable: 100 m  
Diameter: 6,4 mm  
Type: L-(ST)Y EIB  
2 x 2 x 0,8 mm<sup>2</sup> gray

**2**

Application example

clamp                      electronic

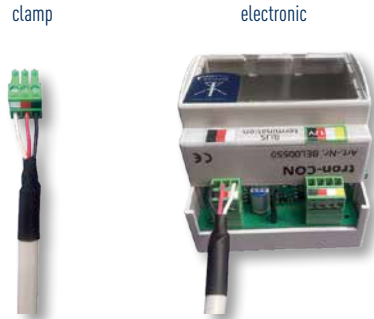





# TAKE THE BEST



**SIHGA® GmbH** | Austria

Gewerbepark Kleinreith 4 | 4694 Ohlsdorf bei Gmunden | Austria | Tel +43 7612 74370 0 | [info@sihga.com](mailto:info@sihga.com)

